

Features and Benefits

1. Flexible and secure connection which allows the repair or connection of damaged or new sections of pipe.
2. Longest “standard” barrel in the industry.
3. The SBR transition gasket is produced from 100% new rubber to ensure excellent performance under varying pressures. Suitable for mild acids, water and salt media with a temperature range of -25 to +200°F.
4. Standard barrel and glands receive an interior and exterior fusion bonded epoxy coating.
5. Angular deflection up to 8°
6. O.D. ranges are cast and molded into glands and gaskets for ease of identification.
7. Working pressure 150 PSI, testing pressure 225 PSI

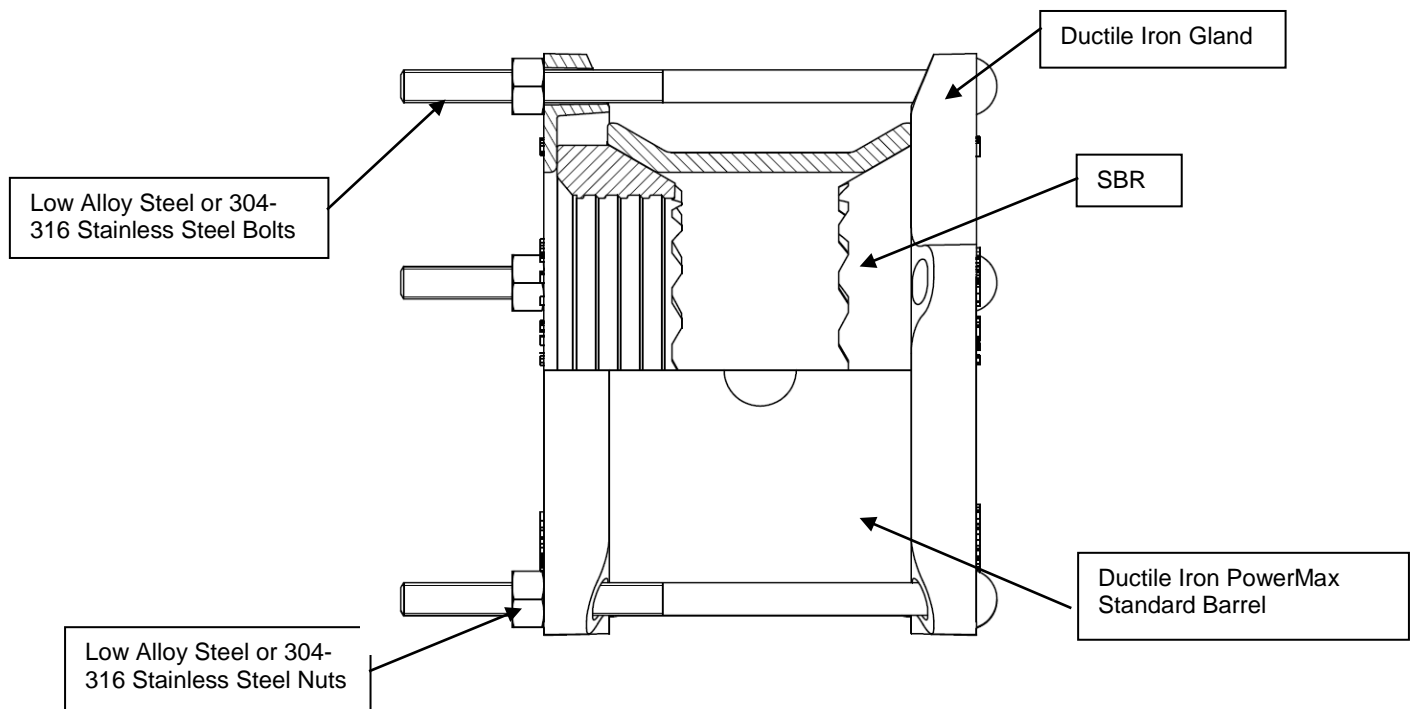

3506

3506LB



Scope

The intent of the specification is to receive 2” - 16” diameter all ductile iron bolted PowerMax couplings which require only one common sleeve and corresponding set of end glands per nominal pipe size. This coupling is capable of fitting a wide range of pipe diameters without interchanging any components. The coupling furnished shall be equivalent to Model 3506/3506LB PowerMax Coupling as manufactured by PowerSeal Pipeline Products Corporation. Meets or exceeds AWWA C219.

Design and Material Specification

The PowerMax Coupling shall meet or exceed all material specifications as listed below and AWWA C219.

1. Gaskets shall be vulcanized, molded or extruded, SBR (Styrene Butadiene Rubber) free from porous areas, foreign materials, and visible defects. Reclaimed rubber shall not be used. Gaskets shall meet the requirements of ASTM D2000 to ensure superior storage characteristics, permanence, and resistance to set. Also available in EPDM or Viton.
2. Bolts and nuts shall be in Low Alloy Steel. Stainless Steel type 304 Nut & Bolts and SST type 316 are available.
3. The laying length of the PowerMax sleeve shall be as specified (i.e., standard or Long-Barrel), and the minimum quantity of bolts shall be as noted per the nominal diameter.

Material Specifications		
Part Name	Material	Mat. specs
Gland	Ductile Iron	ASTM A536
Gasket	SBR	ASTM D2000
PowerMax Barrel	Ductile Iron	ASTM A536
Bolts	Low Alloy Steel/ Stainless Steel 304/316	ASTM A325/ ASTM A193
Nuts	Low Alloy Steel / Stainless Steel 304/316	ASTM A325/ ASTM A194
Coating	Epoxy Coated	AWWA C210

NOMINAL PIPE SIZE		PIPE RANGE	STANDARD BARREL LENGTH (IN.)	LONG BARREL LENGTH (IN.)	BOLTS & NUTS	WEIGHT (LB.)
OD (in)	Letter code				QTY	
2	A	2.30-2.90	5	12	2	16
3	A	3.40-4.20	5	12	3	21
4	A	4.20-5.33	6	12	4	27
6	A	6.25-7.45	6	12	5	36
8	A	8.40-9.79	10	12	6	60
10	A	10.70-12.12	10	12	7	69
12	A	12.75-14.38	10	12	8	83
14	A	15.25-16.90	10.5	12	10	130
16	A	16.00-17.80	12	12	10	155
16	B	17.40-19.00	12	12	10	165

