



POWERMAX FLANGED COUPLING ADAPTER 3526

FLANGE ADAPTER BODY: Ductile Iron per ASTM A536 and AWWA C219.

END GLANDS: Ductile Iron per ASTM A536 and AWWA C219.

GASKET: SBR per ASTM D2000 with conical design produced from 100% new rubber to ensure performance under varying pressures with superior storage characteristics per AWWA C219. Suitable for mild acids, water and salt media with a temperature range of -40° to +200° F.

BOLTS & NUTS: Low Alloy Steel per ASTM A325, ASTM A563, and AWWA C219./ Type 304 (18-8) Stainless Steel per ASTM A193 and A194.Type 316 available.

ANCHOR STUDS: Type 304 (18-8) Stainless Steel. (Optional joint restraint).

FINISH: Epoxy.



Made in U.S.A

MEETS
AWWA
C219



Nominal Pipe Size		Pipe OD Range		Body Length Dim - A		Overall Length Dim - B		Gland OD Dim - C		Approx. Weight		Flanged Adapter List Price					
In	MM	Inches	MM	In	MM	In	MM	In	MM	lbs.	kgs	Part Number Std. Unit	List Price Std. Unit	Part Number Anchor Studs	List Price Anchor Studs	Part Number w/ SST N&Bs	List Price w/SST N&Bs
3	80	3.40-4.20	86-107	6.00	152	8.0	200	8.8	224	23	10.72	352603A00000	391.60	352603A000AS	523.40	352603A0SS00	659.80
4	100	4.20-5.33	107-135	6.28	160	8.8	223	9.94	252	25.2	11	352604A00000	599.20	352604A000AS	731.00	352604A0SS00	921.40
6	150	6.25-7.45	159-189	6.28	160	8.8	223	12.8	325	36	16.3	352606A00000	797.10	352606A000AS	928.90	352606A0SS00	1,171.00
8	200	8.40-9.79	214-249	5.65	143	8.2	208	14.44	367	45	20.45	352608A00000	1,009.20	352608A000AS	1,141.00	352608A0SS00	1,438.40
10	250	10.70-12.12	272-308	10	254	12.5	317	16.85	428	72	32.72	352610A00000	2,104.30	352610A000AS	2,284.50	352610A0SS00	2,498.70
12	300	12.75-14.38	324-365	10	254	12.5	317	20.58	523	102.7	46	352612A00000	2,407.60	352612A000AS	2,587.70	352612A0SS00	3,262.20

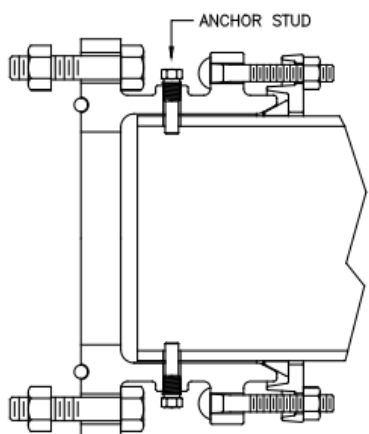
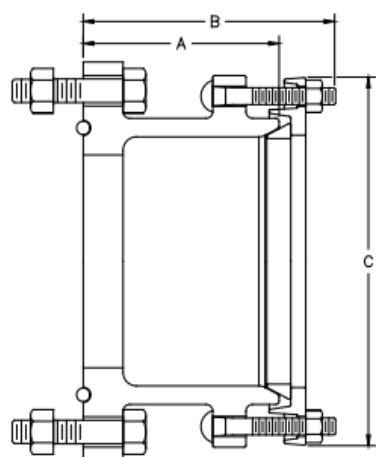

Note: Protection against possible pull out of pipe ends is not provided with cast couplings unless pipe is restrained.

Pipe diameters less than IPS/STEEL rated up to 50 psi work pressure.

HOW TO ORDER: Specify Model Number, Pipe Size with Letter Code. **EXAMPLE:** 6" Flanged Valve to 6" Cast Iron O.D. 7.10. Order 3526 - 6. **Part Number:** 352606A00000.