

**Features and Benefits**

1. Materials do not compromise the integrity of the pipeline.
2. Captive finger stud sub-assembly design makes installation easy and eliminates loose pieces in the field.
3. Due to stainless steel panel construction saddles can be manufactured to fit any pipe diameter.
4. Saddles are available with NPT, BSP or AWWA (CC) tapped outlets 1/2" - 2".
5. Patented NBR tapered end O-ring mat gasket design ensures a watertight seal to all classes of pipe.
6. Stainless steel finger stud sub-assembly fitted with stainless steel washer bar to support nuts, and special Delrin washers for extra lubrication.

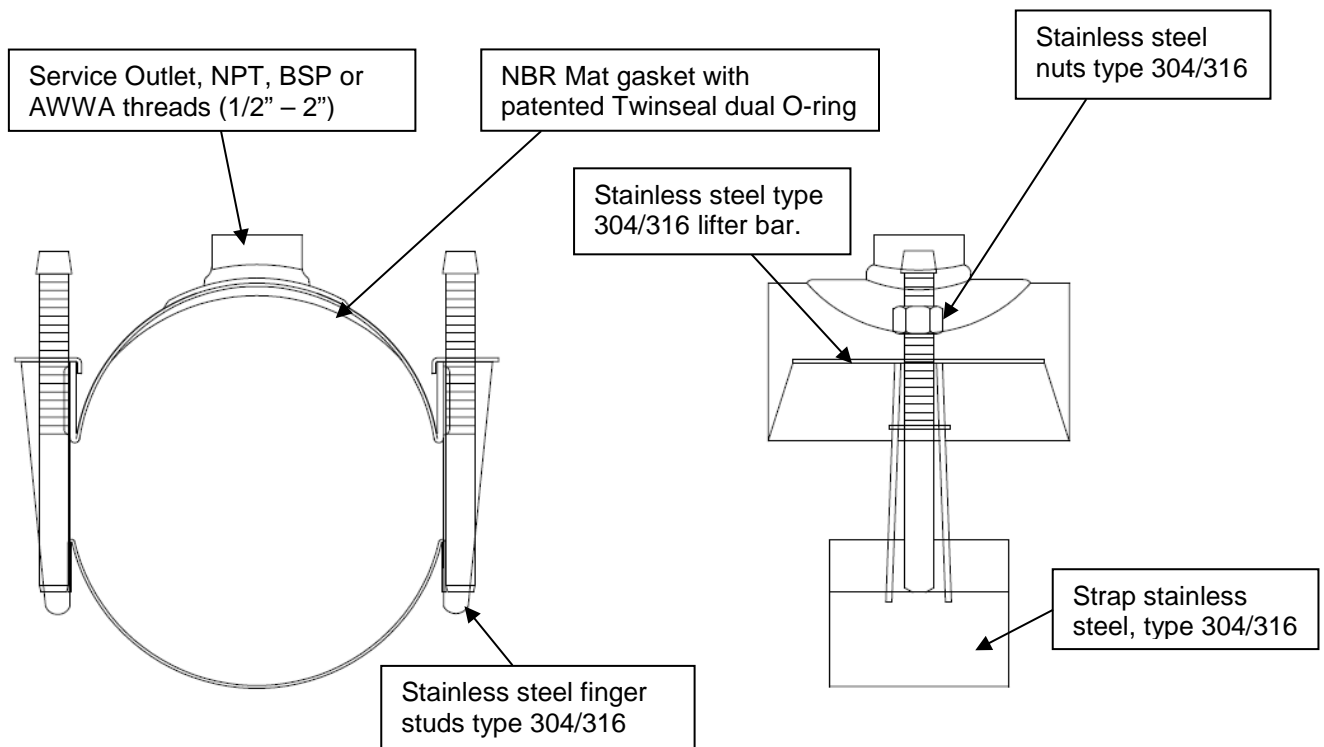

3421AS				
Pipe Size		Pipe OD Range		Strap width
in.	mm.	in.	mm.	in
4A	100	4.36 - 5.66	111 - 114	2" for all sizes
5A	125	5.40 - 6.40	137 - 163	
6A	150	6.45 - 7.75	164 - 197	
8A	200	8.50 - 9.80	216 - 249	
10A	250	10.25 - 11.55	260 - 293	
10B	250	10.95 - 12.35	278 - 314	
12A	300	12.30 - 13.60	312 - 345	
12A	300	13.14 - 14.44	334 - 367	



### *Scope*

The intent of the specification is to receive a 4” – 12” diameter stainless steel saddle. The saddle furnished shall be equivalent to model 3421AS as manufactured by PowerSeal Pipeline Products Corporation.

### *Design and Material Specification*

The stainless steel saddle shall meet or exceed all material specifications as listed below:

1. The exterior band of the Saddle shall be Type 304/316 (18-8) stainless steel.
2. The saddle shall have an O-ring mat gasket with tapered ends permanently attached to the panel at the factory.  
The O-ring mat gasket shall be our patented design in NBR. It shall be free from porous areas, foreign material, and visible defects, all made from 100% new rubber. The NBR resists temperatures of -25 to +248°F.
3. Finger stud sub-assembly shall be permanently attached by way of welding during manufacture at the factory. The weld shall be fully passivated.
4. The stainless steel female outlet shall be permanently attached to the saddle via a fully passivated weld during manufacture at the factory.
5. There shall be no paper or plastic adhesive labels attached to the saddle, any information appearing on the saddle shall be stenciled.
6. Fully complies with AWWA C800 and NSF 61.

Material Specifications		
Part Name	Material	Mat. specs
Panel	Stainless Steel type 304	ASTM A240
Base Plates	Stainless Steel type 304	ASTM A240
Bolts	Stainless Steel type 304	ASTM A193
Nuts	Stainless Steel type 304	ASTM A194
Twineseal Matt	NBR	ASTM D2000
Washerbar	Stainless Steel type 304	ASTM A240
Friction Washer	Delrin Plastic	MIL-A50424