

## 3521 TRANSITION FLANGED COUPLING ADAPTER

**FLANGE ADAPTER BODY:** Ductile Iron per ASTM A536 and AWWA C219.

**END GLANDS:** Ductile Iron per ASTM A536 and AWWA C219.

**GASKET:** SBR per ASTM D2000 with transition design produced from 100% new rubber to ensure performance under varying pressures with superior storage characteristics per AWWA C219. Suitable for mild acids, water and salt media with a temperature range of -25° to +200° F.

**BOLTS & NUTS:** Low Alloy Steel per ASTM A325, ASTM A563, and AWWA C219./ Type 304 (18-8) Stainless Steel per ASTM A193 and A194.

**ANCHOR STUDS:** Type 304 (18-8) Stainless Steel. (Optional joint restraint).

**FINISH:** Epoxy.



Nominal Pipe Size		Pipe OD Range		Body Length Dim - A		Overall Length Dim - B		Gland OD Dim - C		Approx. Weight		Flanged Adapter List Prices						
Inches	MM	Inches	MM	Inches	MM	Inches	MM	Inches	MM	lbs.	kgs	Part Number Std. Unit	List Price Std. Unit	Part Number Anchor Studs	List Price Anchor Studs	Part Number w/ SST N&Bs	List Price w/ SST N&Bs	
4	100	OD	4.00-4.13	102-105	3.0	76	6.5	165	8.8	224	24	11	352104D0000	\$ 283.20	352104D00AS	\$ 364.90	352104DSS00	\$ 460.00
		AA	4.20-4.50	107-144									352104AA0000		352104AA00AS		352104AASS00	
		A	4.50-4.85	114-123									352104A00000		352104A000AS		352104A0SS00	
		B	4.80-5.10	122-130									352104B00000		352104B000AS		352104B0SS00	
		C	5.05-5.40	128-137									352104C00000		352104C000AS		352104C0SS00	
6	150	OD	6.00-6.14	152-156	4.5	114	7.1	181	10.9	227	34	15	352106D0000	\$ 361.60	352106D00AS	\$ 452.00	352106DSS00	\$ 583.00
		AA	6.27-6.72	159-171									352106AA0000		352106AA00AS		352106AASS00	
		A	6.62-6.95	168-177									352106A00000		352106A000AS		352106A0SS00	
		B	6.90-7.22	175-183									352106B00000		352106B000AS		352106B0SS00	
		C	7.19-7.45	183-189									352106C00000		352106C000AS		352106C0SS00	
8	200	OD	8.00-8.16	203-207	4.5	114	7.1	181	13.6	344	47	21	352108D0000	\$ 496.40	352108D00AS	\$ 580.00	352108DSS00	\$ 728.40
		AA	8.40-8.82	213-224									352108AA0000		352108AA00AS		352108AASS00	
		A	8.62-9.05	219-230									352108A00000		352108A000AS		352108A0SS00	
		B	9.05-9.45	230-240									352108B00000		352108B000AS		352108B0SS00	
		C	9.10-9.79	231-249									352108C00000		352108C000AS		352108C0SS00	
10	250	A	10.70-11.10	272-282	4.5	114	7.1	181	16.2	411	68	31	352110A00000	\$ 898.60	352110A000AS	\$ 1,010.30	352110A0SS00	\$ 1,105.00
		B	11.10-11.50	282-292									352110B00000		352110B000AS		352110B0SS00	
		C	11.60-12.12	295-308									352110C00000		352110C000AS		352110C0SS00	
12	300	A	12.75-13.20	324-335	4.5	114	7.1	181	18.6	472	91	41	352112A00000	\$ 999.40	352112A000AS	\$ 1,165.50	352112A0SS00	\$ 1,497.60
		B	13.20-13.50	335-343									352112B00000		352112B000AS		352112B0SS00	
		C	13.78-14.38	350-365									352112C00000		352112C000AS		352112C0SS00	

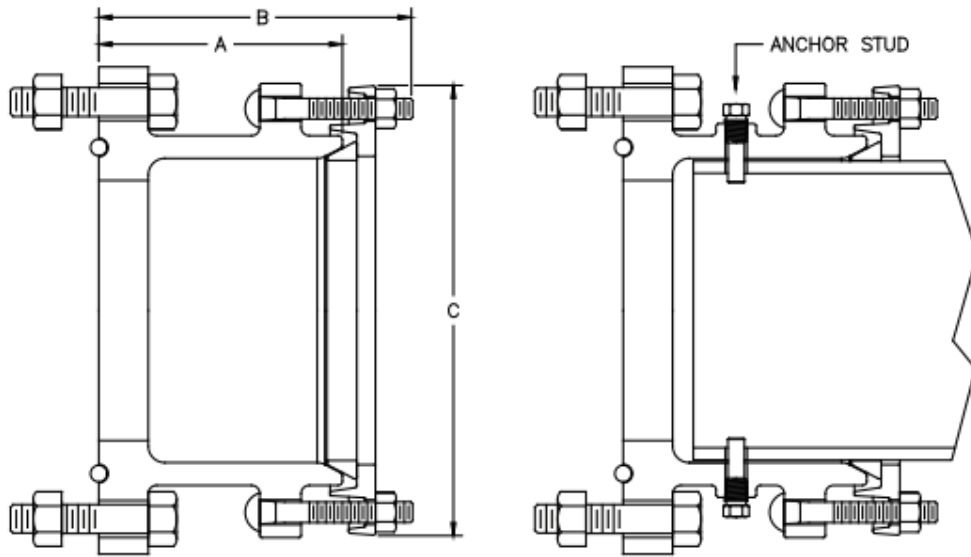

**Note:** Protection against possible pull out of pipe ends is not provided with cast couplings unless pipe is restrained.

**HOW TO ORDER:** Specify Model Number, Pipe Size with Letter Code. **EXAMPLE:** 6" Flanged Valve to 6" Cast Iron O.D. 7.10. Order 3521 - 6B. **Part Number:** 352106B00000 .