

### Features and Benefits

1. Allows use of MJ gate valve, reduces valve inventory and therefore, creates cost savings on valves.
2. The complete tapping sleeve is constructed of 316 Stainless Steel and shall be passivated so as to return the welded stainless steel to its original corrosion state.
3. Built in range allows reduction of inventory.
4. Drop in track head bolts with stainless steel nuts allow assembly in either direction. Available with NEVERGALL coating.
5. 360° complete full circle mat o-ring gasket provides protection against leaks beyond o-ring seal.
6. The branch shall be a minimum of 3/8" larger diameter than nominal to allow the use of a full size cutter.
7. Can be custom built for any pipe OD within limits.

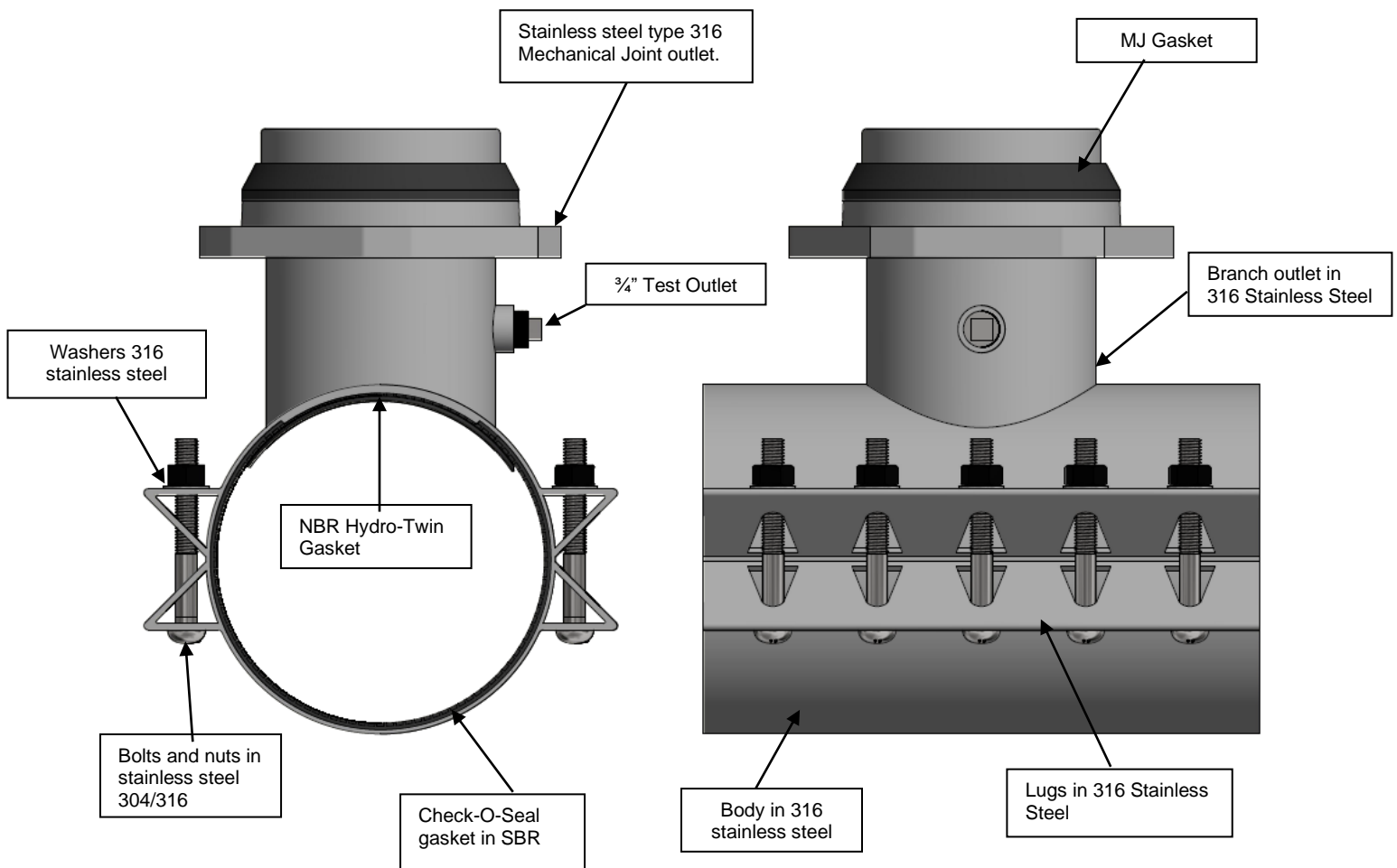

### *Scope*

The intent of the specification is to receive totally 316 stainless steel tapping sleeves with mechanical joint outlet ranging in pipe sizes from 4" and larger and with outlet sizes from 2" to 24". The MJ tapping sleeve shall meet or exceed all material specifications as listed below and be suitable for use with standard mechanical joint x mechanical joint resilient wedge gate valves per ANSI/AWWA C509-94. The tapping sleeve shall comply with AWWA C223. The tapping sleeve furnished shall be equivalent to model 3490MJ-1 stainless steel tapping sleeve with mechanical joint outlet, as manufactured by PowerSeal Pipeline Products Corporation.

### *Sample Design and Material Specification*

**The Tapping Sleeve shall be rated for a maximum working pressure of 250 psi and 312 psi testing pressure for outlet sizes 4" to 8". For outlet sizes 10" and 12" a maximum working pressure 200 psi and 300 psi testing pressure. For pipe sizes larger than 30" a maximum working pressure up to 100 psi and 150 psi testing pressure.**

1. Sleeve Body shall be fabricated completely from stainless steel grade 316 per ASTM A240. All welding shall be passivated so as to return the welded stainless steel to its original corrosion resistant state. All through 24" main size sleeves shall be two-piece and have a 0.40" outside diameter range of fit while 30" and larger main size sleeves shall be three pieces and have a 0.60" outside diameter range of fit.
2. Mechanical joint outlet shall be a one piece casting of 316 stainless steel TIG and MIG welded 360 degrees, with a shoulder and plain end cross sectional profile fully complying with AWWA/ANSI C110/A21.10. The inside diameter of the Mechanical Joint outlet fitting, and the branch shall be larger in diameter by a minimum of 3/8 than nominal size to allow the use of a full size cutter.
3. The Tapping Sleeve shall have a branch sealing gasket with the Hydro TwinSeal® dual o-ring design incorporating both hydrostatic and mechanical forces to affect a dynamic seal. A gridded complete circle gasket attached to the sleeve at the factory manufactured from SBR rated at (-40°F - +200°F). An industry standard mechanical joint outlet gasket complying with ANSI/AWWA C111/A21.11 must be supplied.
4. Lugs shall be fabricated of 316 stainless steel per ASTM A240, and are to be attached by means of a continuous weld (GMAW) to the body of the sleeve on at least one side, and shall be so designed to prevent the rotation of the head of the drop in bolts, and facilitate the installation of the sleeve.
5. The Tapping Sleeve shall incorporate drop-in, oval neck, track-head bolts type 316 (18-8) stainless steel per ASTM A193. Stainless steel 304 heavy hex nuts per ASTM A194.

6. All fluid sealing area welds branch/body, branch/MJ outlet and test plug will be double welded (inside and outside).
7. Each tapping sleeve shall be factory hydrostatically tested at on pipe to verify proper fit and weld integrity with zero leakage allowed and will be designed to withstand the require working pressure.
8. There shall be no paper or plastic adhesive labels attached to the tapping sleeve, any information appearing on the sleeve shall be etched.
9. Consult factory about concerns at proper fit and ranges.
10. The minimum quantity of drop-in bolts per outlet diameter shall be:

Outlet Diameter	Drop-In Bolt Quantity	Mechanical Joint Outlet Bolt Quantity	Tapping Sleeve Width
2"	8pcs	2pcs	12"
3"	8pcs	4pcs	12"
4"	10pcs	4pcs	16"
6"	10pcs	6pcs	16"
8"	12pcs	6pcs	20"
10"	16pcs	8pcs	24"
12"	20pcs	8pcs	30"
16"	24pcs	12pcs	36"

Material Specifications		
Part Name	Material	Mat. specs
MJ Flange Outlet	Stainless Steel 304/316 or Carbon Steel	AWWA C115
MJ Gasket	SBR	ANSI/AWWAC111/A21.11
Branch	Stainless Steel type 316	ASTM A240
Test Plug	Stainless Steel type 316	ANSI B2.1
Shell	Stainless Steel type 316	ASTM A240
Lugs	Stainless Steel type 316	ASTM A240
Hydro-twin	NBR	ASTM D2000
Gasket	SBR	ASTM D2000
Bolt	Stainless Steel type 316	ASTM A193
Nuts	Stainless Steel type 316	ASTM A194

