

PowerSeal is a manufacturer of a full line of pipeline accessory products.

PIPE REPAIR CLAMPS
COLLAR LEAK REPAIR CLAMPS
BELL JOINT REPAIR CLAMPS
FLEXIBLE COUPLINGS
FLANGE ADAPTERS
STEEL FABRICATIONS
EXPANSION JOINT
SEWER COUPLINGS
SERVICE SADDLE
TAPPING SLEEVES
TAPPING TOOLS
AIR RELEASE VALVES
CHECK VALVES
LINE STOP FITTINGS
CUTTING-IN SLEEVES



Represented by:

Casing Chocks

**MODEL
4810**



For positioning Carrier Pipe within Casing

P.O. Box 2014, Wichita Falls, TX 76307, USA

800-800-0932 - 940-767-5566

Features of the PowerSeal Casing Chock

For Centering or Custom Positioning Carrier Pipes within Casing Pipe

PowerSeal Model 4810 Casing Chocks position any type of pipe in a Casing with ease, are virtually corrosion proof, and provide insulating protection from galvanic corrosion between the carrier pipe and casing.

No special tools are needed, no grease is used and they are easily bolted on by a single worker.

These fittings eliminate the time consuming practice of attaching wooden skids to the carrier with straps or bands. Check the following comparison:



Casing Chock eliminate the need to fill the space between the Inside Diameter of the casing pipe and the carrier pipe with sand which is very labor intensive. Sand in the annular space also acts as an electrolyte thereby introducing unwanted current to the steel or ductile iron.

With no need for this fill, Casing Chocks are the only choice today to lower installation cost with continued access for maintenance.

NO NEED TO FILL THE ANNULAR SPACE WITH FILLER MATERIAL



PowerSeal Casing Chocks	Banded Wood Skids
1. Eliminates Blown Sand or Gravel.	1. Requires Filler Material in Annular Space for Support.
2. Installation by One Crew Member guarantees Low Labor Cost.	2. Necessitates Installation by Two or More Workmen.
3. Long term Corrosion Protection.	3. Promotes Bacteria and Differential Oxygen Concentration Corrosion.
4. Long Friction Coefficient assures an Easy Slide.	4. Higher Friction Coefficient requires Excessive Force to Push and Increases Labor Time and Fuel Consumption.
5. Quick Installation.	5. Difficult to Field Construct.
6. Provides Electrical Insulation.	6. Non-Insulating.
7. Factory Adjusted for Gravity Sewer Applications.	7. Very Difficult and Time Consuming to Adjust in the Field.
8. High Strength for Jack and Bore Pushes Prevents Over Belling.	8. Over Belling Expands and Splits PVC Pipe Joints.
9. Easily Secured in Place.	9. Easily Dislodged by Weld Beads and other Protrusions inside the Casing.
10. Retains Polyethylene Wrap on Ductile Iron Pipe.	10. Poly Wrap Gathers, Bunches and Easily Tears During the Push.
11. Provides Pipeline Accessibility For Maintenance.	11. Backfill Material Must Be Removed to Allow Maintenance.
12. Years of Proven Reliability.	12. High Failure Rate.

MATERIALS OF CONSTRUCTION

PowerSeal Type 304 (18-8) Stainless Steel or A36 Carbon Steel Chocks are available in two widths, the 8" Width is recommended for carrier pipe 2" to 14", and 12" Width for carrier pipes 16" and larger. The band is constructed of heavy gauge material with an Electromagnetic PVC liner.

Abrasion resistant dielectric skids prevent damage as the carrier pipe is being installed in the casing and, along with the dielectric inner liner, provide maximum insulation.

Carbon steel spacers are available with a paint primer or with fusion bonded epoxy coatings for extra corrosion protection.

PowerSeal has the experience to custom manufacture virtually any configuration required. From multiple carrier product lines within a single casing, to concentrically fitting a bell and spigot ductile iron pipe within its casing PowerSeal has the experienced personnel to respond to your needs.

Design Options

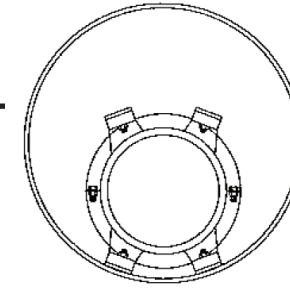

Standard

The standard design allows the carrier to rest at the bottom of the casing.

Center Restrained

The centered option positions and restrains the main carrier in the center of the casing to provide maximum space for other use.

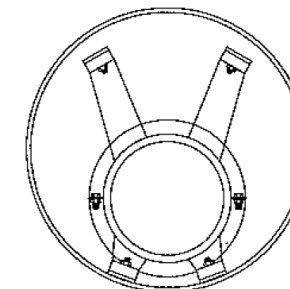
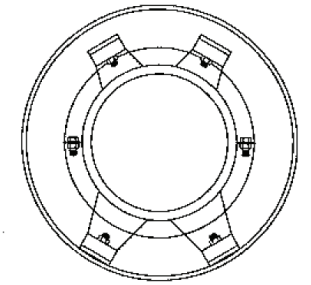

Bottom Restrained

The Bottom Restrained Chock prevents the carrier pipe from floating or buckling within the casing.

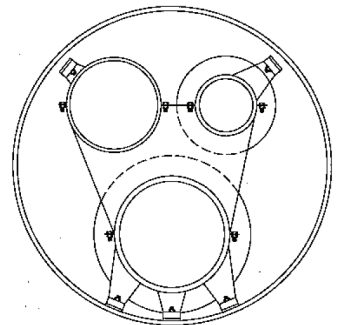

MultiCarrier

Allows casing pipe to be fitted with two or more carrier pipes and/or electrical or communication conduits.

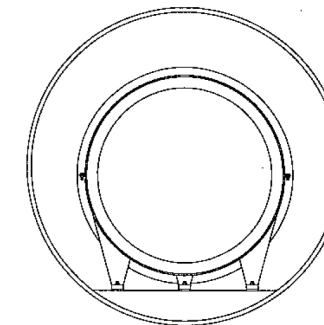

Tunnel Chocks

Large diameter casing tunnels which previously required track systems for the carrier pipe can be accommodated with casing chocks designed to provide full support to a concrete "tunnel floor".

Custom Engineered

The model 4810 Casing Chock is a versatile pipeline fitting that can be custom engineered for most carrier/casing pipe applications such as:

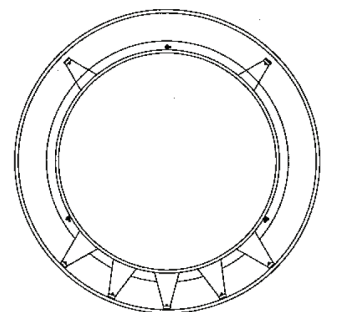

- Correcting Improperly Graded Sewer Casing.
- Centering Pipeline Rehabilitation Sliplining Carriers.
- Positioning Insulated Pipe without Damaging Insulation.
- Placing Gravity Sewer Lines to On-Grade Requirements.

General Guide for Spacing and Positioning Chocks on Carrier Pipe

TYPE OF PIPE	NOMINAL SIZE	INTERVAL	CHOCK WIDTH
Ductile Iron and Steel	To 48"	10'00"	8" or 12"
Ductile Iron and Steel	48" thru 60"	10'00"	12"
Prestressed Concrete	To 36"	10'00"	12"
C900 PVC	All Sizes	10'00"	8"
PVC Sewer	All Sizes	6'00"	8"
Asbestos-Cement	All Sizes	See Note	8"
Polyethylene	All Sizes	4' to 6'	8"

PIPE SIZE	SKID QUANTITY
Up thru 14"	4
16 thru 36"	6
Larger than 36"	7

Note: Consult PowerSeal Engineering for specific design requirements.

Note: Casing Chocks should be placed on both sides of an A/C Coupling for maximum joint stability.

Standard Positioning for Steel and Ductile Iron Carrier Pipes

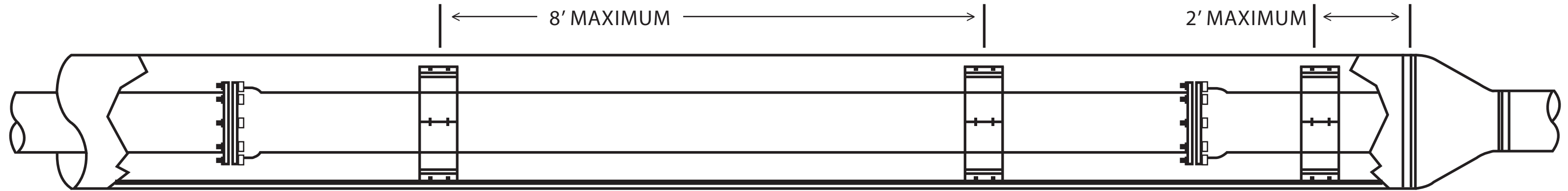

Standard Positioning for PVC Carrier Pipes

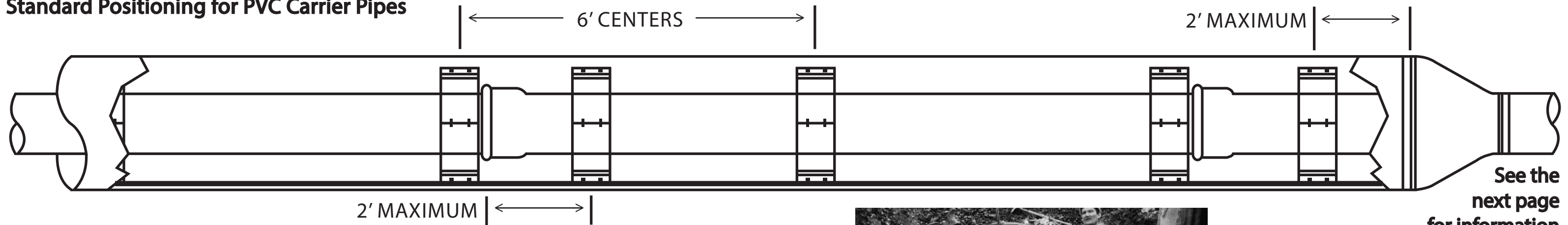

Upon completion of the joint the Chock shall be in contact with the Bell Face of the joint so that the Chock pushes the preceding joint and "over belling" or excessive joint compression is prevented. Additional Chocks are to be positioned at 6' intervals within the Casing.



See the next page for information on EndSeals.

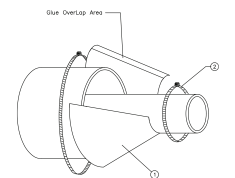

EndSeals

For Sealing the Annular Space Between Casing and Carrier Pipes at the Ends of the Casing

EndSeals may be manufactured for any carrier/casing differential. They are used to create a seal between the carrier pipe and casing to insure filler material is maintained within or foreign objects kept put of the annular space.

And, unlike link-type sealing blocks that are limited by the carrier/casing differential and can only be used on a concentric profile, these EndSeal are totally flexible. They are constructed from 1/8" thick synthetic rubber assuring excellent chemical resistance and resiliency.

These products out perform the costly and labor intensive brick and mortar method of sealing casing ends.

While soil stress and pipe movement cause mortar to crack, the EndSeal moves with the pipe, insuring the integrity of the seal.

The PowerSeal wraparound design facilitates installation when the carrier line has already been installed and the job is complete.

Simply wrap the EndSeal around the carrier and casing pipes, press the industrial grade hook and loop strips together, and secure with the stainless steel clamps.

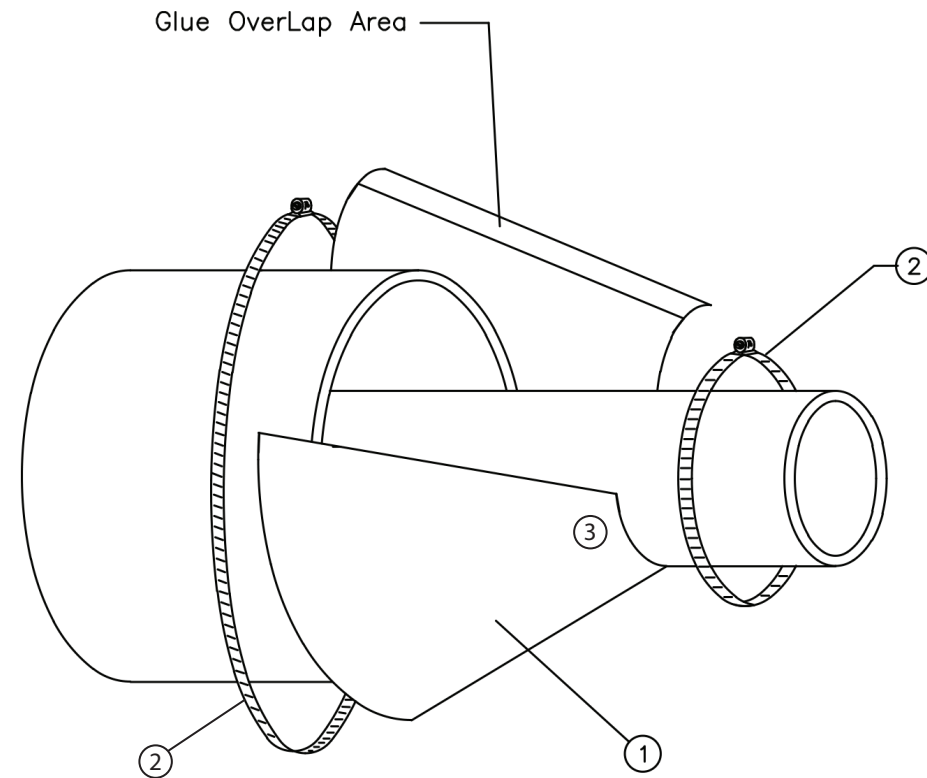

1. Elastomeric Body 2. Stainless Steel Clamps 3. Hook & Loop Seal

WHEN ORDERING CASING CHOCKS PLEASE PROVIDE THE FOLLOWING INFORMATION

- Engineering Firm Name, Job Name, and Bid Date
- Outside Diameter and Manufacture of Carrier Pipe
- Type of Joint, i.e. Mechanical Joint, Push-On, Flanged, Restrained, etc.
- Inside Diameter and Type of Casing Pipe
- Length of Casing and/or Quantity of Chocks
- Casing Chock Design, i.e. Standard, Centered, Restrained
- Special Installation requirements such as Leak Detection Cable, Special Clearance, etc.

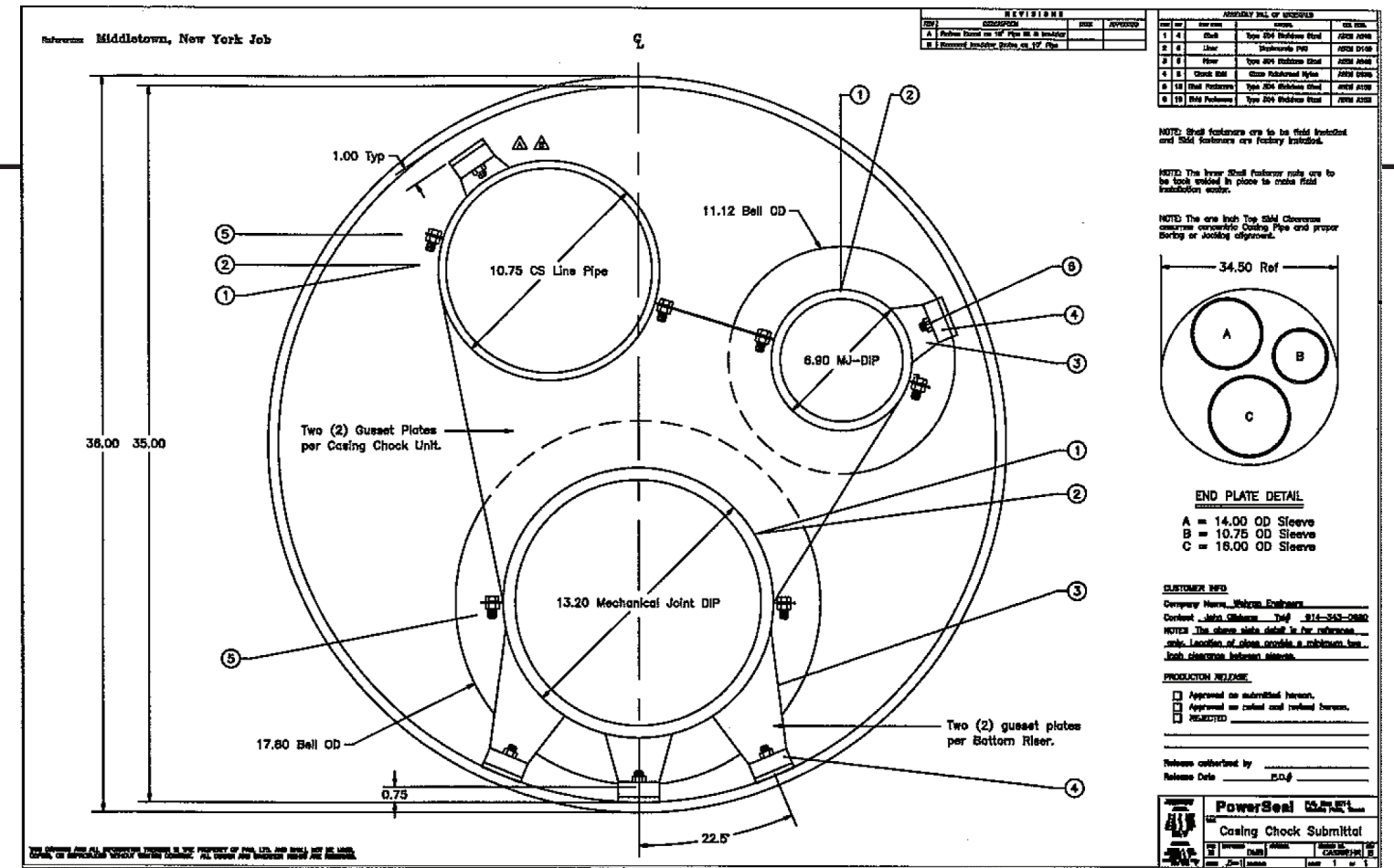

PowerSeal provides detailed Submittal Drawings for Contractor Approval on all applications.

Sample Specification

General Design

1. The Casing Chock shall have a bolt-on Shell made in two sections with Ribbed Flanges.
2. The Casing Chock shall have a Liner to isolate the Shell from the carrier pipe.
3. The Casing Chock shall have Skids attached to the Shell and shall be designed to provide a minimum of 0.75 inches clearance between the carrier pipes' greatest outside diameter and the casing pipe's inside diameter. The Risers shall be precision designed and fabricated to place the Skids in full contact with the inside surface of the casing pipe. This is a critical design element to evenly distribute the load force to all support members (see illustrations).

Material Specifications

1. All metal components shall be Type 304 (18-8) Stainless Steel, or approved equal.
2. The Liner shall be Elastomeric PVC, or approved equal.
3. Chock Skids shall be Fiberglass Reinforced Nylon, or approved equal, with abrasion resistance, high compressive strength, and a friction coefficient of not more than 0.12.

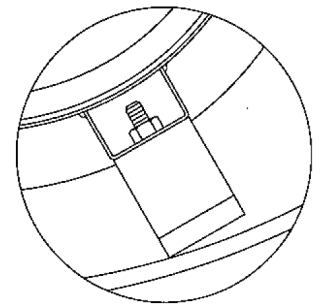

Channel Shaped Riser

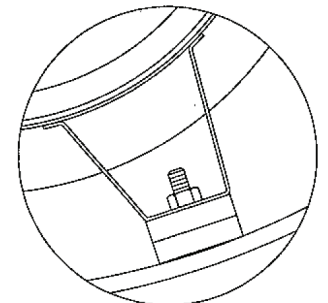

Custom Shaped Riser Provides Precision Fit