

Features and Benefits

1. Materials do not compromise the integrity of the pipeline.
2. Stud bolts MIG welded to straps, heavy hex nuts with fusion bonded coating to prevent seizing and galling.
3. Saddles are available with NPT, or AWWA (CC) tapped outlets 1/2" - 2".
4. NBR O-ring gasket design incorporating both hydrostatic and mechanical forces to produce a dynamic seal.
5. Standard epoxy coating applied to ductile iron top casting.

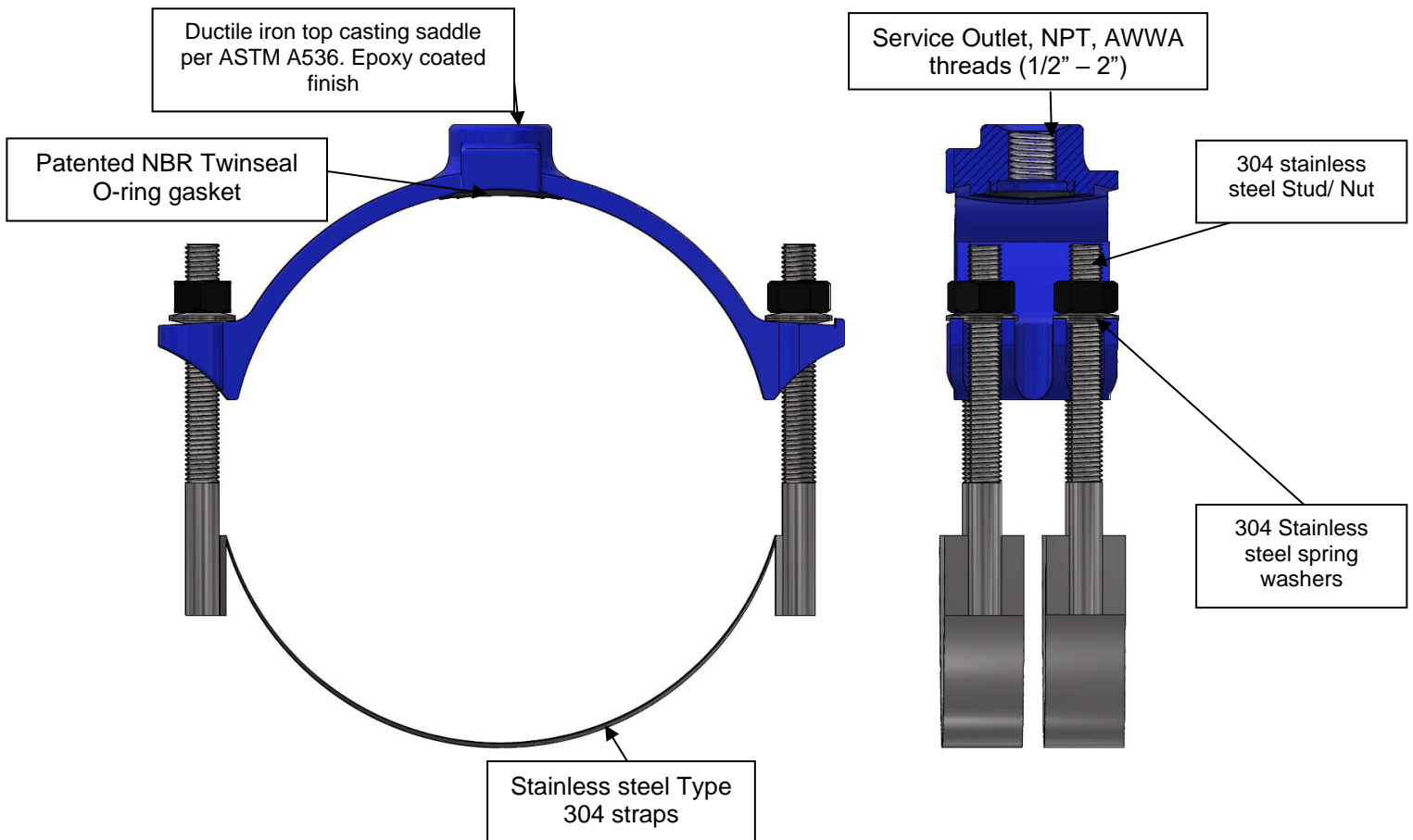

Waterworks pipes can experience changes due to temperature and pressure depending on the field conditions. High-Density Polyethylene Pipe (HDPE) possesses mechanical and thermal properties that cause the expansion or contraction of the pipe because of these changes. 3417DI-PE with spring washers design will support those possible pipe changes without compromising the tightness of the saddle.

Scope

The intent of the specification is to receive a 2” – 24” diameter ductile iron saddle with stainless steel straps. The saddle furnished shall be equivalent to Model 3417DI-PE as manufactured by PowerSeal Pipeline Products Corporation.

Design and Material Specification

The saddle shall be rated up to 300 psi working pressure. The ductile iron saddle shall meet or exceed all material specifications as listed below.

1. The top casting of the saddle shall be ductile iron as per ASTM A536.
2. The saddle shall have an O-ring gasket permanently attached to the casting at the factory. The O-ring gasket shall be the in NBR. It shall be free from porous areas, foreign material, and visible defects, all made from 100% new rubber. The NBR resists temperatures of -40 to +248°F.
3. The MIG welded strap shall be stainless steel type 304. 5/8” stainless steel 304 stud bolts shall be welded to the straps and passivated to return the corrosive resistance
4. The (AWWA or NPT) threaded outlet shall be individually CNC machined and inspected at the factory.
5. There shall be no paper or plastic adhesive labels attached to the saddle, any information appearing on the saddle shall be ink stenciled.
6. Spring washers in stainless steel type 304 per ASTM A240.
7. Fully complies with AWWA C800 and NSF 61.

Material Specifications		
Part Name	Material	Mat. specs
Saddle Top	Ductile Iron	ASTM A536
Strap	Stainless Steel Type 304	ASTM A240
Nuts	Stainless Steel Type 304	ASTM A193
O-Ring Gasket	NBR	ASTM D2000
Spring washers	Stainless Steel Type 304	ASTM A240

Model 3417 DI-PE



Pipe Size		Pipe OD Range			Straps Width
in.	mm.	letter code	in.	mm.	in.
2	50	A	2.38-2.50	61-64	1.5" each strap
3	80	A	3.5	89	
		B	3.45-4.05	88-103	
4	100	A	4.00-4.50	102-114	
		B	4.74-5.63	120-143	
		C	4.74-5.14	120-131	
6	150	A	6.00-6.63	152-168	
		B	6.84-7.64	174-194	
		C	6.63 - 6.90	168-175	
8	200	A	8.00-8.63	203-219	
		B	8.54-10.10	216-257	
		C	8.63 - 9.05	219 - 229	
10	250	A	10.00-11.10	254-282	
		B	10.64-12.12	270-308	
	300	A	12.00-13.20	305-335	
		B	12.62-14.32	321-364	
12-14	300-350	A	14.73-15.65	374-398	
16-18	400-450	A	17.40-18.88	442-480	
18	450	A	19.5	495	
20	500	A	21.6	549	
24	600	A	25.8	655	