

Features and Benefits

1. The dismantling joint shall meet or exceed all material specifications as listed below and AWWA C219.
2. 150 PSI working pressure. This pressure will vary according to the design and the size.
3. Liquid epoxy coating inside and outside of the dismantling joint to prevent corrosion. Fully NSF 61 certified.
4. The dismantling joint makes it easy to install a flanged product in a new or existing setting.
5. Allows some deflection for misaligned assemblies.
6. It does not require special tooling and it is available for a wide variety of types and sizes.
7. Joints are restrained when tie rods are used to secure the flange fittings, making other joint restraint unnecessary.
8. This product can be used with flange fittings like butterfly valves and pumps.

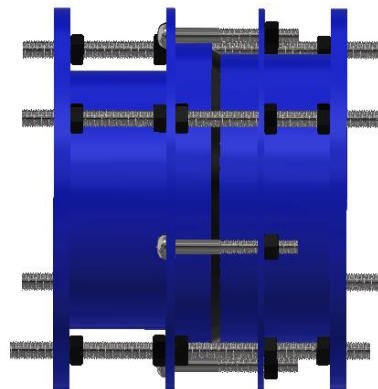
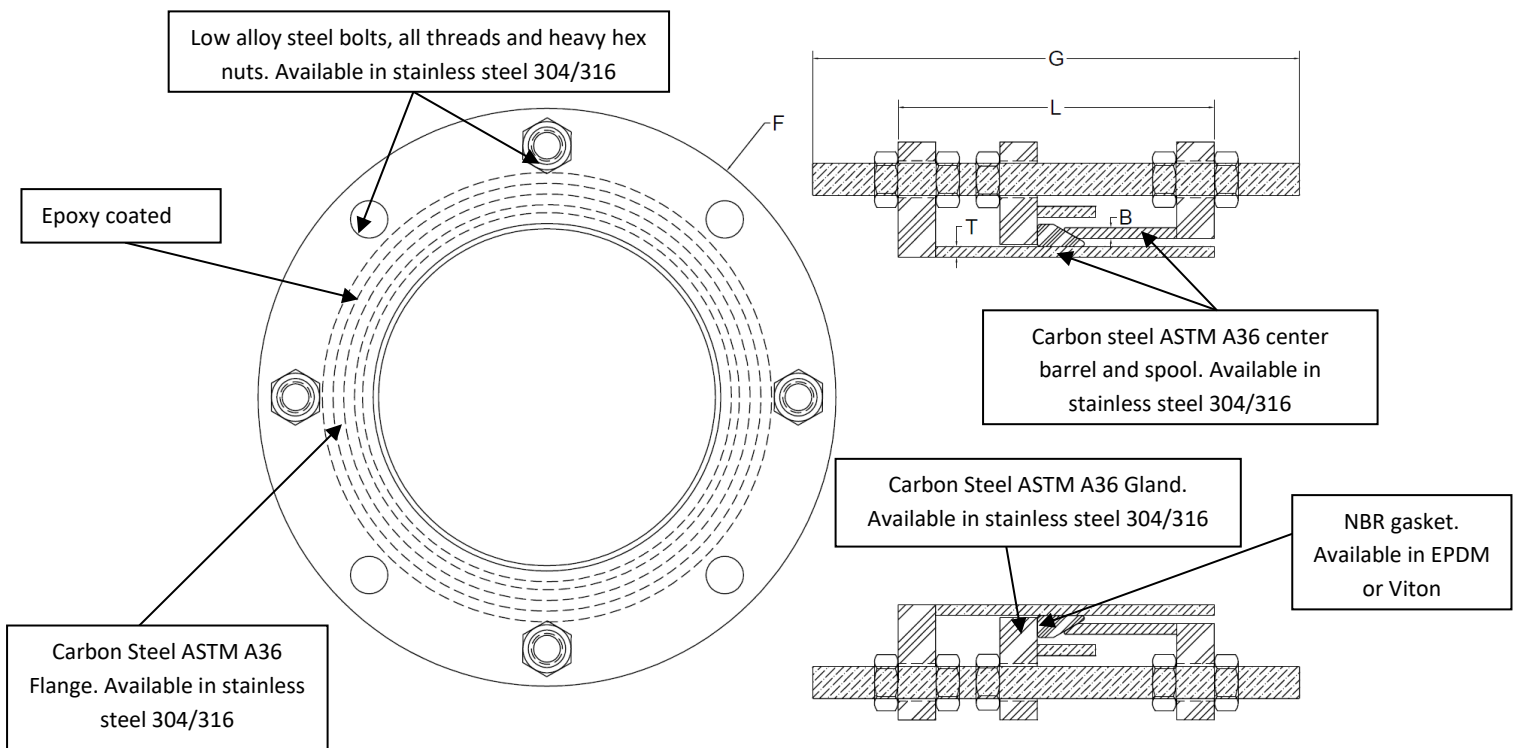

Nominal size	Dimensions				Length X		Tie Rods		Follower Bolts		Spool THK	Barrel THK
	Flange OD	Flange ID	FLANGE B.C	Flange THK	Min	Max	Size	QTY	Size	QTY	E	F
	A	B	C	D								
3	7.50	3.58	6.00	0.625	9.00	11.00	5/8 x 14	4	N/A	N/A	SCH 40	SCH 40
4	9.00	4.57	7.50	0.625	9.00	11.00	5/8 x 14	4	N/A	N/A	SCH 40	SCH 40
6	11.00	6.72	9.50	0.688	9.00	11.00	3/4 x 16	2	5/8 x 4.5	4	1/4	1/4
8	13.50	8.72	11.75	0.688	9.00	11.00	3/4 x 16	2	5/8 x 4.5	4	1/4	1/4
10	16.00	10.88	14.25	0.688	9.50	11.50	7/8 x 18	4	5/8 x 4.5	4	1/4	3/8
12	19.00	12.88	17.00	0.812	9.50	11.50	7/8 x 18	4	5/8 x 4.5	4	1/4	3/8
14	21.00	14.19	18.75	0.938	12.00	15.00	1 x 24	4	5/8 x 4.5	8	1/4	3/8
16	23.50	16.19	21.25	1.000	12.00	15.00	1 x 24	4	5/8 x 4.5	8	1/4	3/8
18	25.00	18.19	22.75	1.062	12.25	15.25	1 1/8 x 20	4	5/8 x 4.5	8	1/4	3/8
20	27.50	20.19	25.00	1.125	12.25	15.25	1 1/8 x 20	4	5/8 x 4.5	8	1/4	3/8
24	32.00	24.19	29.50	1.250	12.75	15.75	1 1/4 x 24	4	5/8 x 4.5	12	1/4	3/8
30	38.75	30.19	36.00	1.375	13.25	16.25	1 1/4 x 26	7	5/8 x 4.5	16	1/4	3/8
36	46.00	36.19	42.75	1.625	14.25	17.25	1 1/2 x 30	8	3/4 x 4.5	20	1/4	3/8
48	59.50	48.18	56.00	1.875	15.25	18.25	1 1/2 x 30	11	3/4 x 4.5	24	1/4	3/8

Scope

The intent of the specification is to receive dismantling Joints fabricated in carbon steel ASTM A36 (available in stainless steel 304/316) from 4” (80mm) up to 30” (750 mm) of nominal pipe size. The dismantling joint furnished shall be equivalent to the model 3563 as manufactured by PowerSeal Pipeline Products Corporation and it will meet or exceed AWWA C219.

Design and Material Specification

1. The dismantling joint shall be fabricated in carbon steel per ASTM A36 or any other steel having a minimum yield of 30,000 psi.
2. Dismantling Joints shall provide adjustability to equipment installations by combining a Flanged Coupling Adapter and Flanged Spigot into one assembly. Longitudinal adjustment shall be accomplished by the telescoping action of the Spigot inside the Flanged Coupling Adapter.
3. The flanges shall be AWWA C207 class D ring flange, compatible with ANSI class 125 and 150 bolt patterns.
4. The follower gland shall be fabricated in carbon steel per ASTM A36 or any other steel having a minimum yield of 30,000 psi
5. The NBR per ASTM D2000 gasket is produced from 100% new rubber to ensure excellent performance under varying pressures. Suitable for water, oil acids, alkalis, most (aliphatic) hydrocarbon fluids and many other chemicals, with a temperature range of -25 to +248°F. Other materials as EPDM or Viton are available
6. Bolts, nuts and all threads shall be in low alloy steel per ASTM A242 and ASTM A563 – Stainless steel 304 or 316 are available.

7. The bolts for the flange coupling adapter shall be round head oval neck as same as the holes for the gland to facilitate the adjustment of the nut with one tool.
8. The flanges must allow bolts according to the standard ANSI B16.1 and the all threads must have the same diameter to go through the dismantling joint.
9. The dismantling joint must allow a minimum displacement of 2” (50mm).
10. The dismantling joint shall be epoxy coated to prevent rust and corrosion.

Material Specifications		
Part Name	Material	Mat. specs
Gland	Carbon Steel/ Stainless Steel 304-316	ASTM A36 / ASTM A240
Gasket	NBR /EPDM or Viton	ASTM D2000
Flange	Carbon Steel	AWWA C115
Body	Carbon Steel/ Stainless Steel 304-316	ASTM A36 / ASTM A240
Bolts	Low Alloy Steel / Stainless Steel 304/316	ASTM A242/ ASTM A193
Nuts	Low Alloy Steel / Stainless Steel 304/316	ASTM A563/ ASTM 194
Coating	Epoxy Coated	AWWA C210

